

RAILWAY CENTRAL TRAFFIC CONTROL SYSTEM APIS-90/CTC

GENERAL TECHNICAL DESCRIPTION

Ver. May-2003

(APIS_TD_GENER2-iap.doc. no.: 437030001)

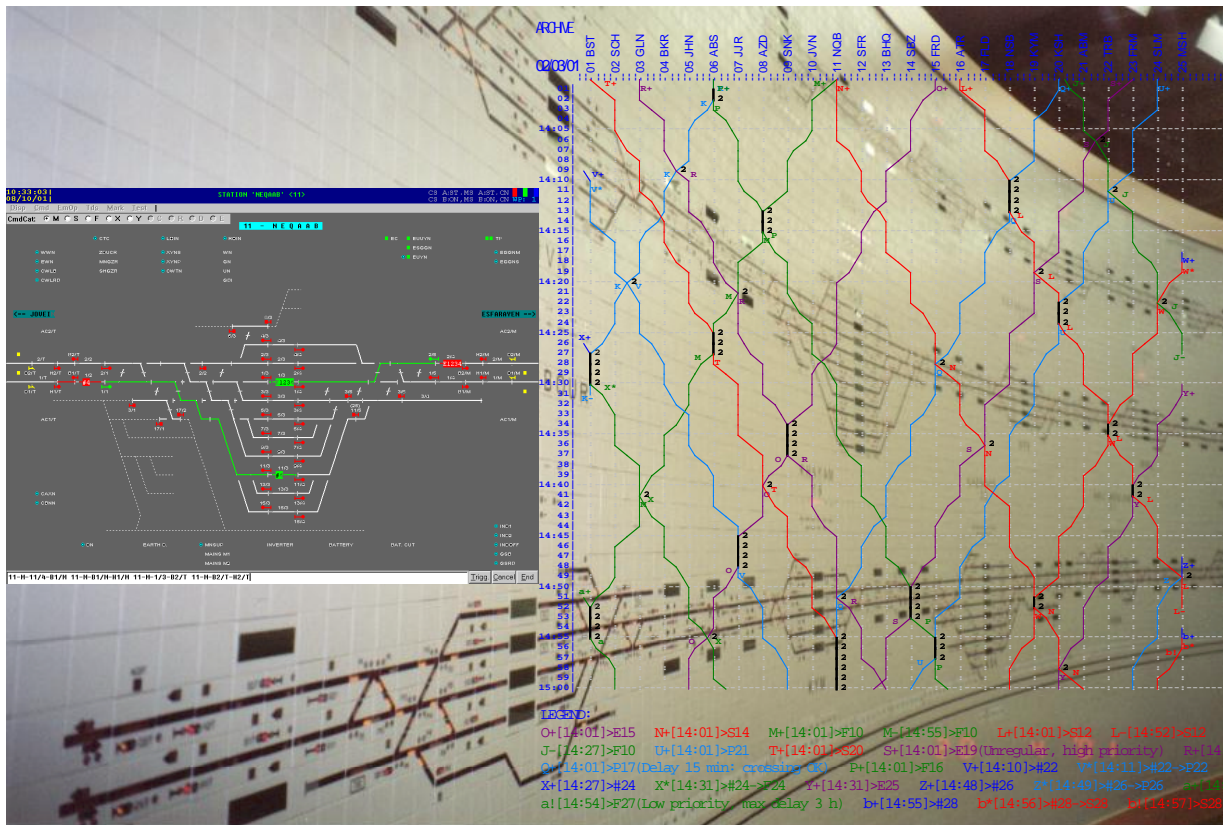

NOTE:

Copyrights I.A.P., Stegne 21, SI-1000 Ljubljana, SLOVENIA. All rights reserved. Information in this document is subject to change.

CONTENTS

1	CHARACTERISTICS AND FUNCTIONS	6
2	GENERAL SYSTEM STRUCTURE	9
3	CTC CENTER	6
3.1	Overview.....	6
3.2	Application software architecture	9
4	REMOTE TERMINAL UNITS	6
5	TECHNICAL DATA	11

LIST OF FIGURES

Figure 1-1	Entire conceptual functional module of railway traffic control (open architecture) of the system APIS-90/CTC.....	7
Figure 2-1	Global Communication architecture of the system APIS-90.....	9
Figure 2-2	Principle of CTC center - RTU interconnection	10
Figure 2-3	Principle of CTC - CTC centers interconnection	10
Figure 3-1	General principled structure of complex CTC center APIS-90.....	7
Figure 3-2	Doubled computer MS_CS basic functional model.....	8
Figure 3-3	Apis-90/CTC center application software architecture	10
Figure 3-4	Railway line simulator tool	11
Figure 3-5	TU-90 software package	12
Figure 4-1	RTU/CG hardware block diagram	6

1 CHARACTERISTICS AND FUNCTIONS

The system APIS-90/CTC is a contemporary computer supported system for local and central railway remote control with the emphasis on effective disposition (overview, coordination, and optimization) and automatic traffic control. The selection of structure and basic function pool enables an optimal relation between price and performances in the following examples of use:

- Local railway traffic control at large railway stations
- Central railway traffic remote control (CTC systems)

The system APIS-90/CTC contains the complete pool of railway traffic control function modules, which enable an optimal adaptation on an individual example of use, fig. 1-1. The basic characteristics of this function pool are:

- Effective support of operator's supervision of routes and traffic (detailed and survivable displays of railway lines on color monitors, indication panels and/or projection systems on modern LCD technology basis, alarm functions)
- Train number following and corresponding support functions of passenger informing, traffic disposition and automatic control
- Effective support of automatic following of traffic running and registration (traingraph, event protocols, traffic diary, reports)
- Effective support of administrative activities (take-over procedures and protocols)
- Automatic programmable traffic control on train number and timetable basis with the support of alternative solutions in the case of conflict states
- Automatic programmable control of shunt routes
- Possibility of direct manual control of routes and interlocking equipment via workposts. The operator enters commands by coding on "start-destination" or "object-function" principle, by mouse on station layout displays on monitors and standard keyboard (imitation of classic control panel)

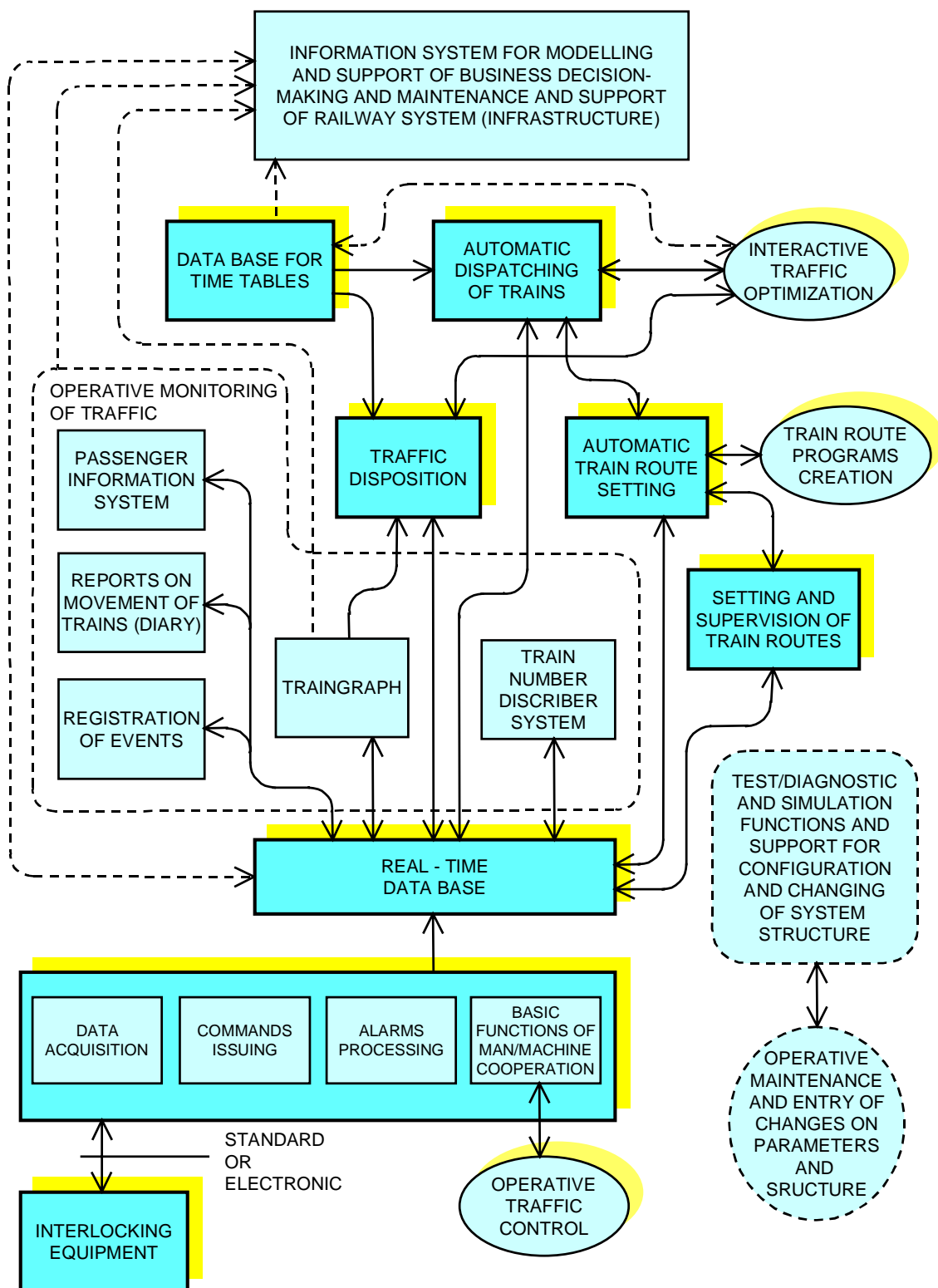

Figure 1-1 Entire conceptual functional module of railway traffic control (open architecture) of the system APIS-90/CTC

- Support of more workposts for control or overview only with one or more monitors with an effective support for mutual competence sharing and protection against unauthorized interventions and data access
- Special system support of "off-line" maintenance and browsing of timetable base and automatic control programs (support of traffic technologist)
- Flexible interfaces between relay or electronic interlocking equipment and CTC system
- Spontaneous diagnostic and centralized information of errors (type and location etc.) and self-documentation of CTC system operation (for maintenance purposes)

The selection of computer components enables a successive and up to date modernization of the system according to current computer and communication technology state. This can be made without or with minimal interventions into application software.

Effective computer equipment and flexible modular concept enable implementation and an effective operation of all the functions for traffic remote control and supervision on the selected APIS-90/CTC area, as the added functions which improve traffic control quality and efficiency too.

The general characteristics of the system APIS-90/CTC are:

- Great operation availability and fault-tolerant operation on the 1 of 2 configuration basis
- Support of "on-line" system servicing (in 1 of 2 configurations)
- It is based on programmable logic controllers (PLC) for realization of interface functions to relay type interlocking equipment
- It is based on programmable communication gateways for realization of interface functions to electronic interlocking equipment (front-end functions and specific protocol conversation)
- It is based on general purposes computers (servers and/or workstations) and periphery devices (color monitors, keyboard, mouse, printer's etc.)
- It is based on redundant Ethernet LAN technology
- Support of standard and proprietary communication protocols for remote and local data transmission
- Application software on standard operating systems, TCP/IP network support and standard languages for programmable logic controller programming
- Modular and open system architecture
- Possibility of regional centralized or decentralized and distributed system realization
- Minimal investment of stations arrangement for building in the system
- Simple projecting, putting the system into operation, and its maintenance
- Simple adaptation to requests and modifications on the spot

APIS-90/CTC system enables maximum investment safety. It has a long life cycle, small maintenance cost, great effect on economy and safety of railway traffic.

2 GENERAL SYSTEM STRUCTURE

The basis of the system APIS-90/CTC is the remote process bus RPB, fig. 2-1. It is doubled for the assurance of necessary availability, and works on 1 of 2 principle. RPB executes the following functions in real time:

- mutual connection of system APIS-90/CTC remote control centers with other (neighboring and local) traffic control systems, with remote station APIS-90 RTU for direct connection on relay (RIEQ) or electronic (EIEQ) interlocking equipment. Interface to RIEQ is based on programmable logic controllers and interface to EIEQ is based on dedicated programmable communication gateway.

Protocol for data transmission among stated systems (indications, commands, train numbers, working parameters etc.). The protocol is based on standard IEC TC 870-5. Digital and analogue telecommunication systems can be used for data transmission media.

- The analogue telecommunication system has been realized by aid of baseband modems, which support "multi-point" (bus) transmission channel configuration, e.g. modem MD 19200 for data transmission on telephone cables.
- For remote communication via digital telecommunication communication system (e.g. Optical Transport Systems), the system APIS-90/CTC needs standard support of 56 or 64 kbps DDS (Digital Data Service) services, fig. 2-2 and 2-3.

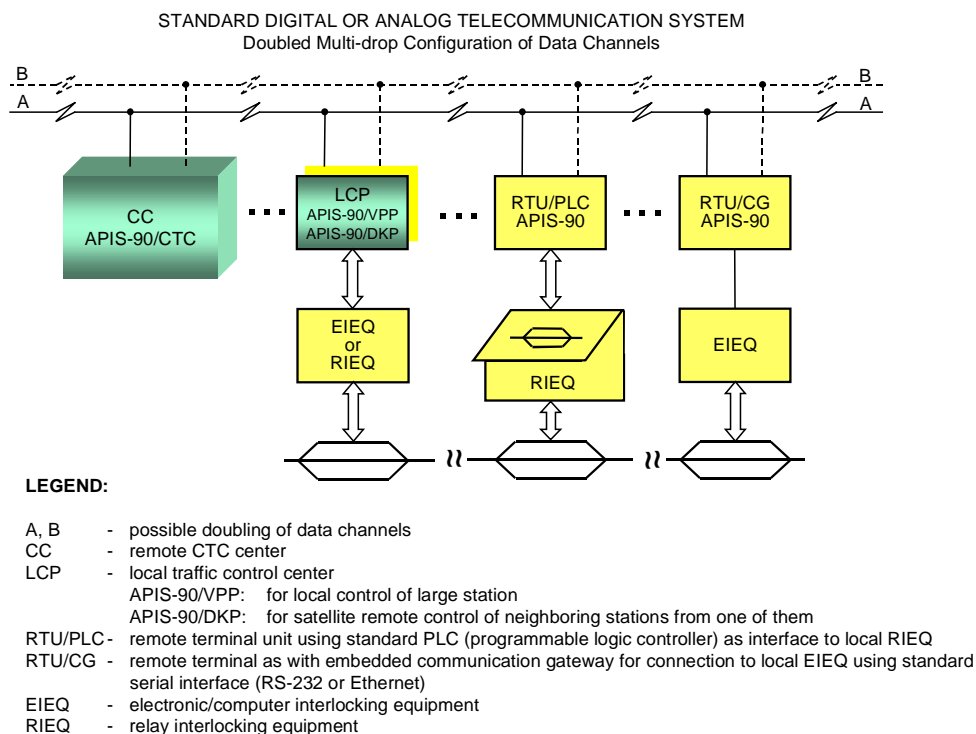

Figure 2-1 Global Communication architecture of the system APIS-90

- ◇ For interconnection of CTC center with RTU network system needs DDS and DSU/CSU support for point-to-point and/or multi-point mode of operation. The DTE (Data Terminal Equipment) interface shall be RS-232 data channel full or semi-duplex asynchronous.
- ◇ For connections between CTC centers, frame relay support can be also used (instead of point-to-point / multi-point support). The DTE interface shall be RS-232 or V.35. This structure enables the actual decentralized operation of the whole control system: the neighboring systems can direct exchange of the train number at crossing from one area to another irrespectively of control center working conditions. The high operating autonomy of individual neighboring and local control center is reached in this way, and so high availability and responsibility of the system.

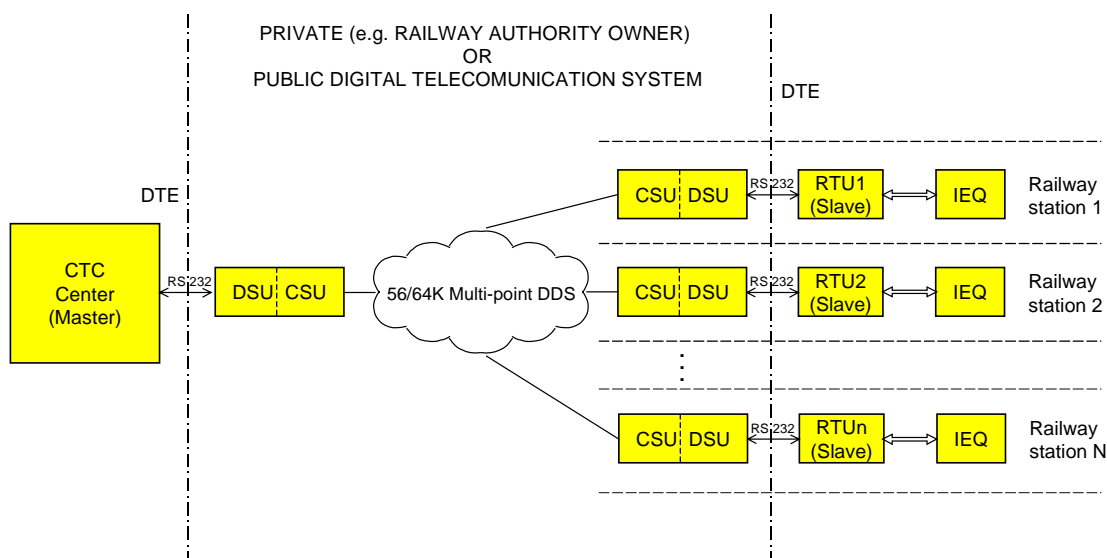

Figure 2-2 Principle of CTC center - RTU interconnection

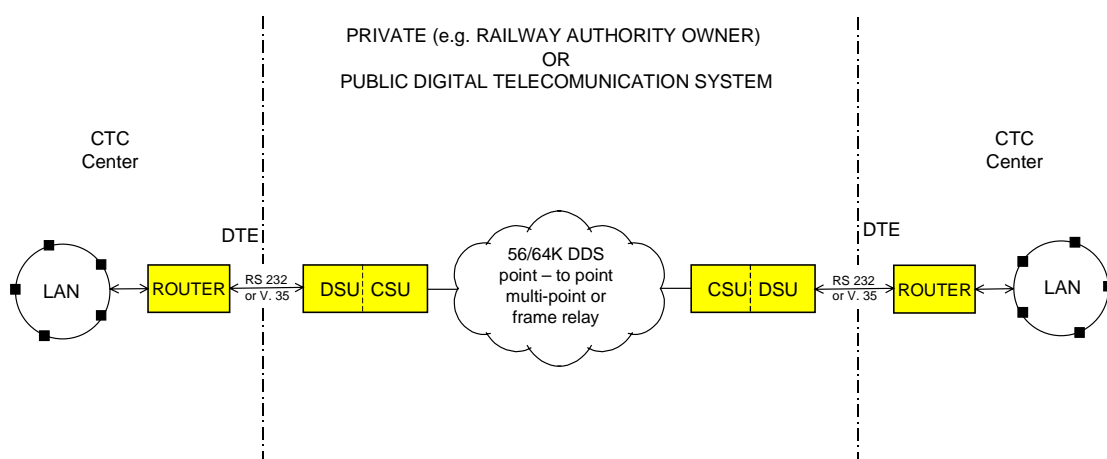

Figure 2-3 Principle of CTC - CTC centers interconnection

3 CTC CENTER

3.1 Overview

Overview of the components of the CC (CTC center for local or remote) railway traffic control are on fig. 3-1.

The basis is a local computer network – Ethernet with redundancy for automatic reconfiguration in case of failure. The following system elements are in the network: MS (main server), CS (communication server) WPS (workpost station), and PS (printer server).

MS includes real time railway database, time table base, and software for train number following, indication and display; overview and control with command execution, automatic train routes setting, events protocol, traffic diary, diagnostic protocol, traingraph, display control on indicating panel etc. A system console SYSC is part of MS for the maintenance functions support of the system.

CS and corresponding operating and application software enable CC communication with other parts of the system over the given telecommunication system in real time. The basic task of this communication is an acquisition of process data (indications, train numbers) and transmission of necessary process data (e.g. commands for routes control, train number movement etc.), which are necessary in the subordinate parts of the system. It can communicate with other CC or business centers over standard networks for data transmission, too.

Integrated version of MS+CS subsystem (implemented on common computer hardware) is normal solution, but separate subsystem are also possible.

WPS realizes MMI (man machine interface) on operator workposts. The individual WPS supports MMI by the aid of max. 3 color monitors with high resolution, standard keyboard and mouse. All MMI procedures are graphically and interactively oriented and based on windows technology, pop - up menus, buttons and dialog windows (spontaneous messages and notes, data entry). MMI procedures have been realized so that the system controls the operator and prevent incorrect actions (function masking and data filtering).

WPS enables operator's functions execution on single or more color monitors so that a great review and MMI efficiency is reached. The number of MMI functions changeover is minimized, e.g. the operator uses one monitor for detailed display of selected station, the second monitor for actual time table observation, over the third monitor he controls automatic routes setting.

The overview display of railway line state of the whole controlled area can be realized as classical indication panel or as color monitors projection subsystem.

Indicating panel overview display can be realized by the aid of the intelligent controller of LED and train number displays, which are integrated into the panel frame. The connection MS - indicating panel is made by doubled twisted pair cable (standard RS - 485) for greater reliability. The control drivers on indicating panel can be doubled too. The breakdown of the whole overview display is inhibited in this way (graceful functions degradation).

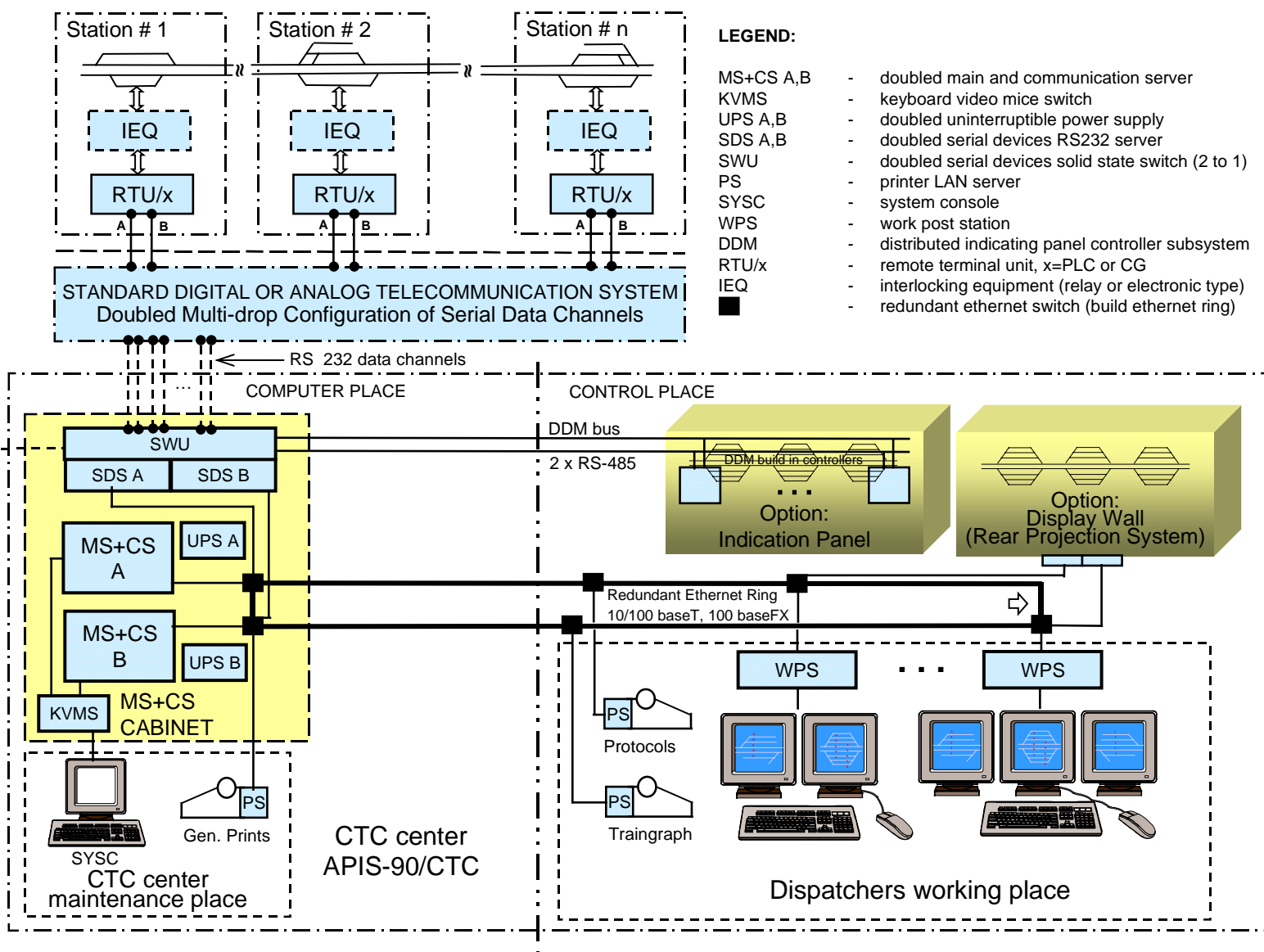

Figure 3-1

General principled structure of complex CTC center APIS-90

May 2003

GENERAL TECHNICAL DESCRIPTION
CTC CENTER

- Test unit:
- Sim. of CTC center against RTUs
 - Sim. of RTUs against CTC center
 - spying of CTC center RTUs communic.
 - DDM controllers (for ind. panel) config. and test utility

Color monitor based projection system overview display can be realized by the aid of more color monitors or by the aid of projection computer processed and controlled picture on a big screen. The basis of the last case is color TFT LCD technology and computer controlled optical system for projection of a picture from LCD screen on the big screen. This technology has great priority in ergonomically sense (clear picture, good contrast, good visibility at day light etc.), it has great reliability, long life-cycle, simple and cheap maintenance.

Overall CC architecture is designed so, that single point of CC total failure doesn't exist. All the vital parts of CC and communication interconnection are doubled in principle, and they operate in 1 of 2 configuration (fault tolerance). According with this, MS+CS subsystem are doubled for synchrony operation in on-line (primary) /standby (secondary) operation with automatic switchover in case of computer failure. Ethernet LAN is redundant automatic re-configurable multi-segment ring. This ring configuration is supported with corresponding (smart) Ethernet switches. All serial communications (to RTUs, indication panel, etc.) are doubled. There are usually more workposts in the system. They are all configured for the whole pool of operator's functions and can be a spare post to each other.

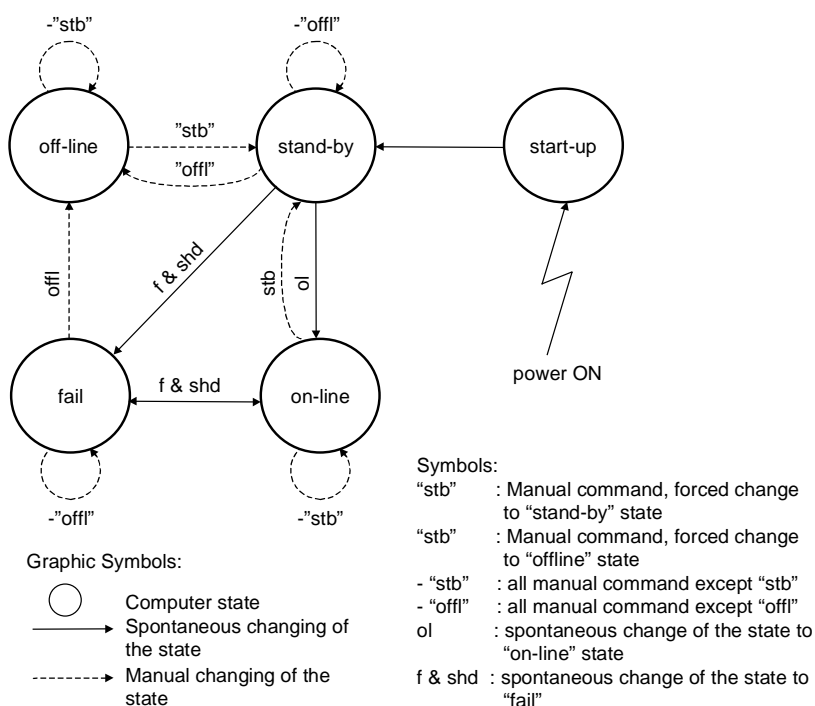

Figure 3-2 Doubled computer MS_CS basic functional model

The hardware configuration on fig. 3-1 is principled and it is used in the complex CC. The high configuration flexibility of CC (which based on horizontal architecture, scalar structure, transparency and modularity of application software) enables hardware compact solution according of particular demands. Even, the realization of a small CC with only one computer is possible but without of CTC functions degradation.

3.2 Application software architecture

Overview of application software architecture for CTC center is given in figures 3-2 and 3-3 and correspondent legends.

Main features:

- ◆ Based on Microsoft Windows NT platform (Microsoft Windows NT/2000/XP platform)
- ◆ High application flexibility due using of engineering tables (Microsoft Excel format) as direct entry to application software
- ◆ Not special drivers used
- ◆ Symmetrical (peer to peer) client server architecture for Remote Procedure Call (RPC) as base for global communication and interaction between main software modules
- ◆ High modularity and efficiency for operation in real time as result of
 - ◇ optimization of overall application software package decomposition in main modules/ components which operate as concurrent and independent processes according Windows NT notation
 - ◇ encapsulation of software components, which are common for more application modules in dynamic link libraries (DLL)
 - ◇ additional local (internal) execution time optimization of particular main module/ component due multi-thread real-time architecture
 - ◇ compact hierarchy model of database in form of relation
 - ◇ implementation of large database for operation in real-time: maintenance of database in RAM instead on disk, using of hash algorithms for fast data access
 - ◇ report by exception (event driven processing) as basic principle of data processing in all part of the system
 - ◇ spontaneous messages provision like as an system wide data bus which support of even driven processing on flexible, modular and unique manner
- ◆ Robust, reliable operation due high operation autonomy of particular software module
- ◆ Efficient support for fault tolerant operation in real time of overall system due synchrony operation of doubled MS_CS server computers in online/ standby cluster configuration and fast automatic switch over capability of this servers in case of any failure inside current online server occurs
- ◆ Fault tolerant and graceful degradation operation for communication against RTUs and indication panel DDM controller subsystem in case of doubled communication channels implemented
- ◆ Fast and independent modules startup
- ◆ Configuration self documentation capability
- ◆ Simple installation/ reinstallation (installation update) procedure
- ◆ Simple system administrative supervision
- ◆ Support for simple and efficient system operation monitoring on build in system console level

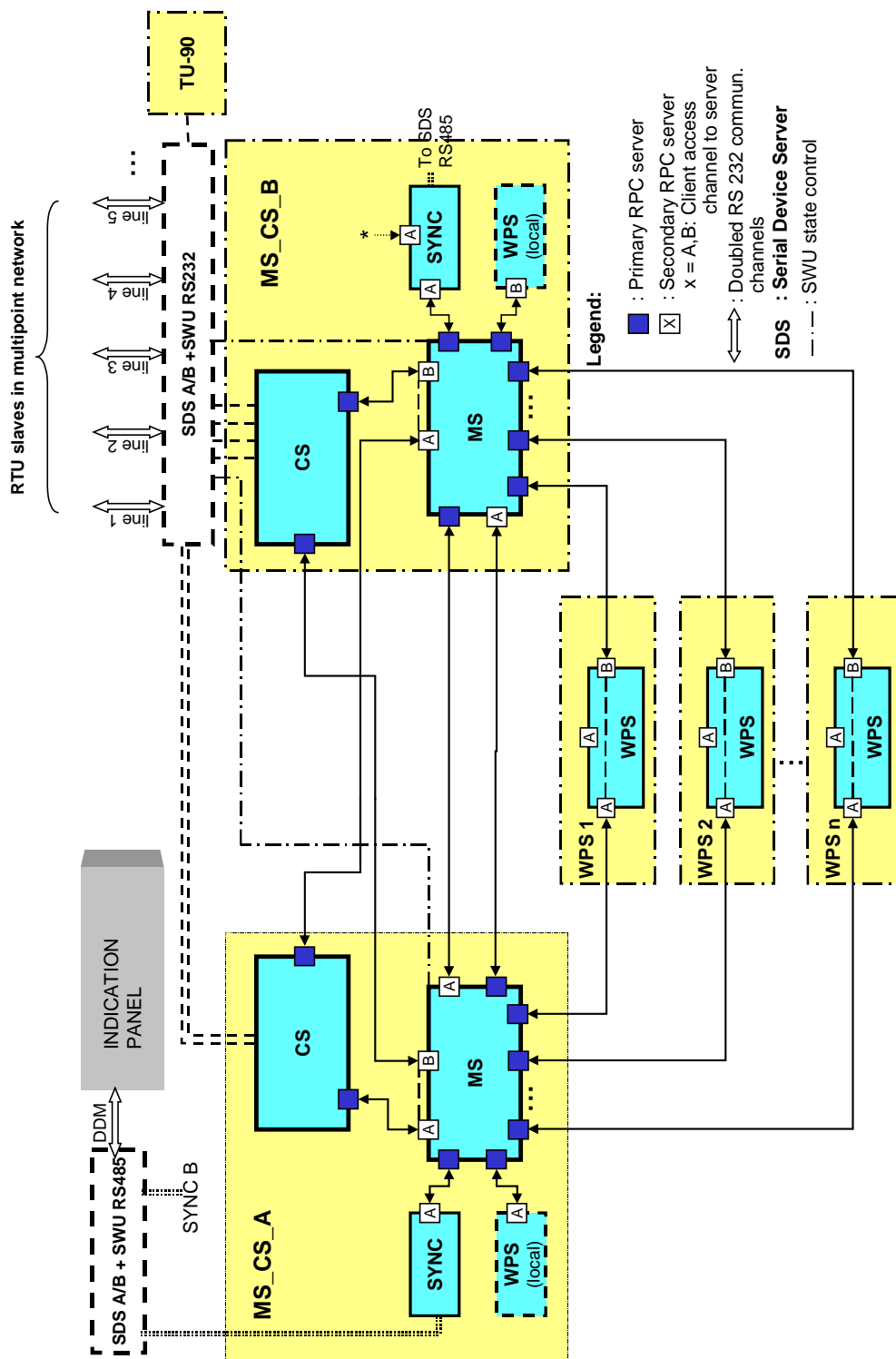

Figure 3-3 Apis-90/CTC center application software architecture

- ◆ Special support of application intensive testing and operation demonstration based on advanced simulation tools for railway line interlocking operation, trains movements and RTUs (Separate simulation computer “RLS” has been use). This support is intended to be use in phase of application building and testing on “factory” location and as support for user’s personal training, Fig. 3-4.

- ◆ Special simulation and spy software tools as part of portable test unit TU-90 for test and monitoring of system operation on communication interface level against RTUs and DDM controller subsystem for indication panel, Fig. 3-5.

Legend - Application software architecture (for Fig. 3-3 and Fig. 3-4)

RLS - Railway Line related Simulator's tools installed in single computer

RLS: Software module *Apis_RLS* in configuration for complete railway line (simulation of interlocking equipment operation and trains movements against CTC centre)

RTU_{Ix}, x=1...n: Software module *Apis_RTUSIM* in configuration for operation on communication line x (simulation of RTU operation against CTC centre)

MS_CS_A - Main and Communication Server computer, subsystem A

and

MS_CS_B - Main and Communication Server computer, subsystem B

MS: Software module *Apis_MS* (Main Server package)

CS: Software module *Apis_CS* (Communication server package)

SYNC: Software module *Apis_SYNC* (Synoptic (Indication) Panel Display Generation and Control)

WPS local: Software module *Apis_WPS* as local WPS console with disabled control functions (supervision and print functions enabled only), intended for maintenance purposes only

WPS x, x=1,...,n- Work Post (workstation) computers

WPS Software module *Apis_WPS* as full operational work post console

Note: Software module is multithread process

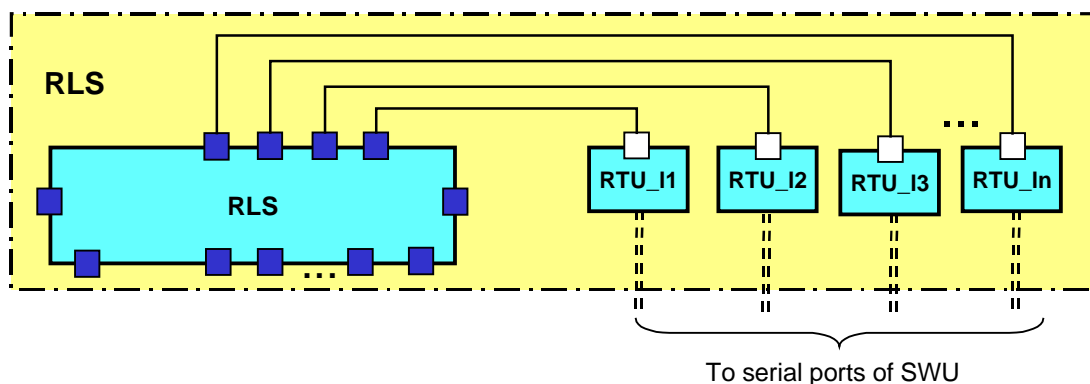

Figure 3-4 Railway line simulator tool

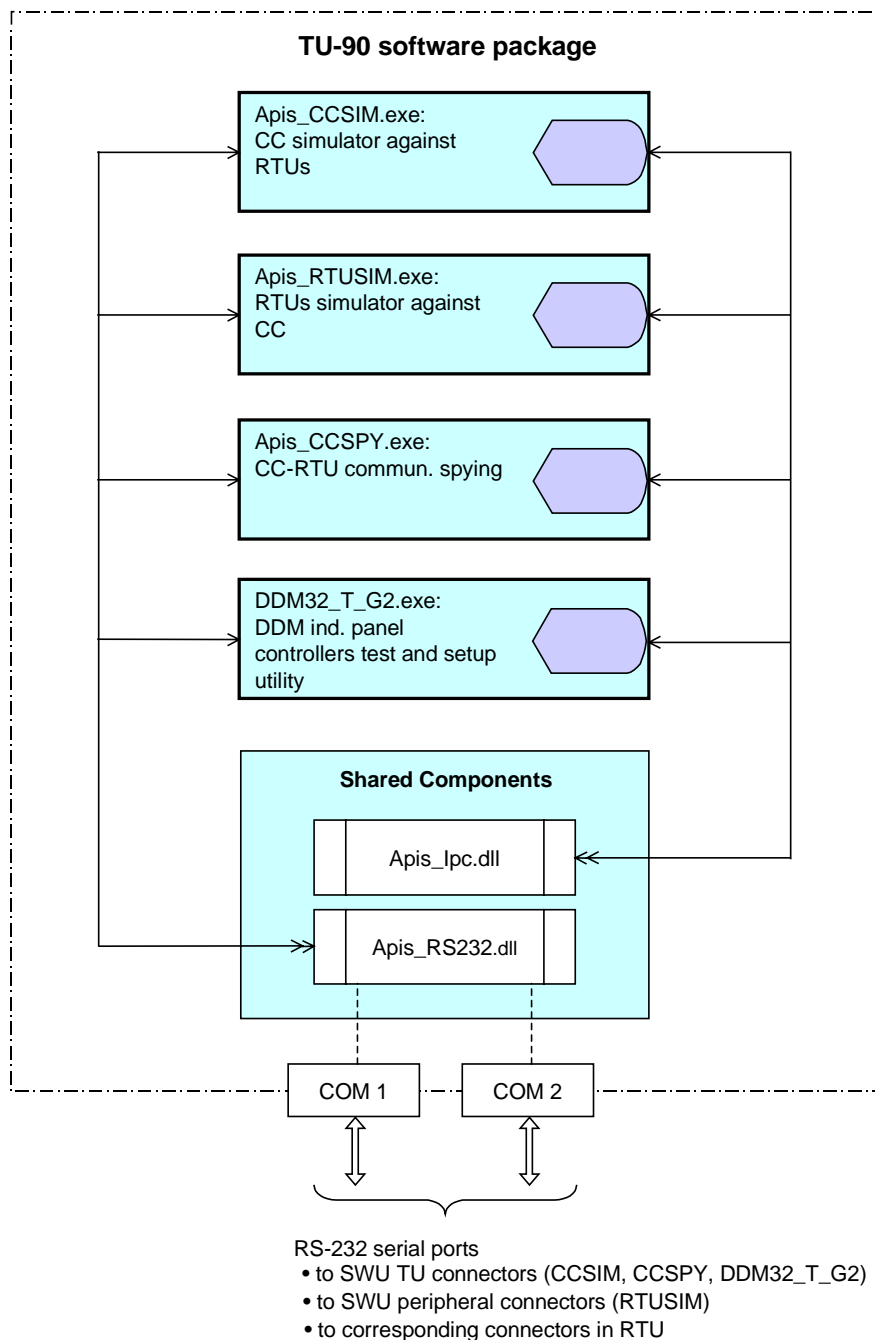

Figure 3-5 TU-90 software package

4 REMOTE TERMINAL UNITS

Railway stations belonging to CTC system control region incorporate relevant electronic subsystems – Remote Terminal Units (RTU), as the CTC center remote interface to the interlocking equipment (IEQ) in particular railway station.

RTU basic functions are:

- Acquisition of indications from the interlocking system,
- Issuing commands to the interlocking system,
- Execution of specific front-end functions (indication filtering and preprocessing for CTC center, checking and issuing CTC command procedures) ,and
- Maintaining remote communication data-link with the CTC center.

System APIS-90/CTC incorporates two basic types of RTUs as follows:

RTU/PLC - RTU for interface with classical relay IEQ (RIEQ) using industry standard programmable logic controllers (PLC) for implementation of parallel (digital input/ outputs) interface with IEQ on local “control panel” level.

RTU/CG - RTU for interface with up to date electronic/ computerized IEQ (EIEQ) using programmable Communication Gateway technology for solving of conversion between APIS-90 remote communication protocol and (in most cases proprietary) “control panel” communication protocol, which is determined by particular EIEQ supplier.

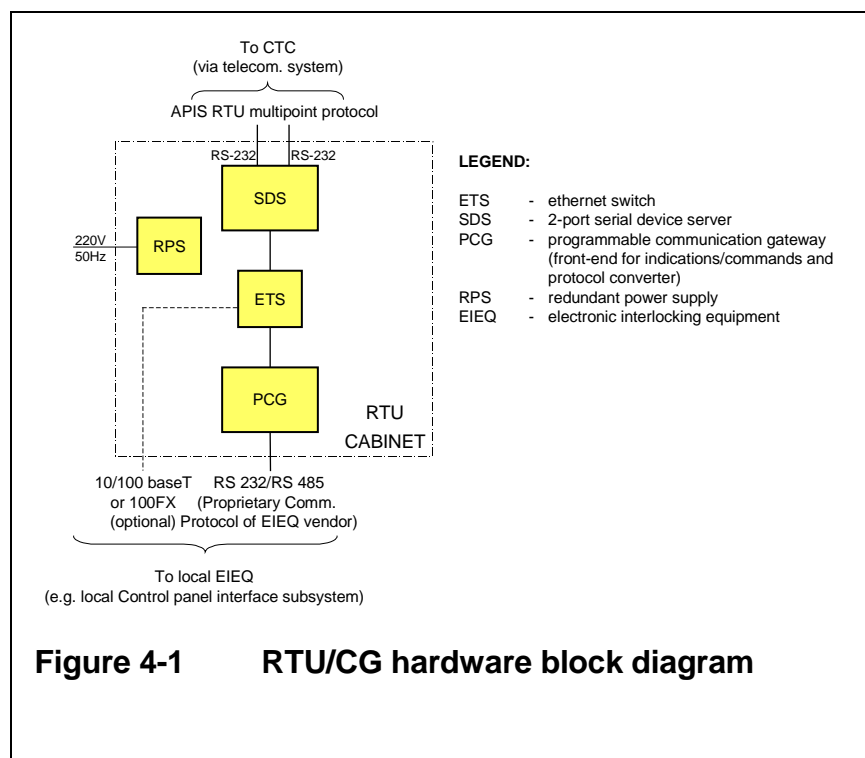

Figure 4-1 RTU/CG hardware block diagram

5 TECHNICAL DATA

- Capacity of one control center
 - Information volume up to 3000 points and signals
up to 20000 commands
 - Number of stations up to 50
 - Number of workposts up to 10 (max.)
- Electrical connection characteristics with classic (relay) interlocking equipment
 - Indicating inputs
 - Type input voltage or potentially free relay contact
 - Insulation voltage 1500 V
 - Command outputs
 - Type potentially free relay contact, individual or group connection
 - Insulation voltage 1500 V (winding - contact)
- Connection with electronic interlocking equipment
 - Electric interface..... serial connection according to standard RS-232C or RS-422/485 and/or Ethernet UTP connection 10/100 baseT or 100 baseFX (fiber optic)
 - Protocol one of standard protocols or propriety protocol (defined by interlocking equipment supplier)
- Communication protocol for remote data transmission (CTC center - RTUs)
 - Protocol characteristics:
 - Type standard realization: remote protocol of the APIS-90 system (standard IEC 60870)
 - Transmission speed 600, 1200, 2400, 4800, 9600 or 19200 bps
 - Data integrity geometric code (protocol APIS-90), min. Hamming distance: $H_d = 4$, undetected error probability: 10^{-12} for indications, 10^{-14} for commands at bit error probability 10^{-4}
 - Updating indications time up to 3 s at 2400 bps and 7 remote stations on a line

- Transmission lines for remote data transmission
 - Communication channels configuration
 - Type doubled, "point to point", "multipoint"
 - Operation mode duplex or semiduplex parallel asynchronous/ synchronous operation on both channels - dual channel data transmission
 - Interface RS-232

 - Transmission media *standard* digital telecommunication system, e.g. Optical Transport System via DSU-CSU which must support multipoint mode of operation

option: analog (twisted pair cables + baseband modems)

- Computer equipment
 - CTC center
 - Computers..... standard Intel processors based computers (servers and/or workstations), desktop or industrial 19" rack for building into cabinet or command desk according to standards
 - Operating system Standard
(MS Windows NT/ 2000/XP)
 - LAN Ethernet switches for 10/100 baseT Ethernet in redundant ring configuration
 - Serial ports Standard serial port servers
 - Video or LCD color monitors
 - Size and resolution min. 17", min. 1024 x 768

- Remote terminal units
 - RTU/PLC industry standard PLC modular system
 - RTU/CG. standard: serial devices server, LAN switch, programmable communication gateway

- Power supply 220 V \pm 15 % , 45-60 Hz, in CTC center build-in power supply autonomy is min, 15 minutes

- Operating conditions (VDE 0831)
 - Control center temperature: 5 °C to 40 °C
humidity: 20 % to 80 % non-condensing

 - Remote station temperature: 0 °C to 60 °C
humidity: 5 % to 95 % non-condensing